

Features

VOLTAGE	100 V
CURRENT	10X2 A

- Ultra Low Forward Voltage Drop
- Excellent High Temperature Stability
- Patented Super Barrier Rectifier Technology
- Soft, Fast Switching Capability

Mechanical Data

- Case: TO-220AB
- Case Material: Molded Plastic, UL Flammability Classification Rating 94V-0
- Terminals: Matte Tin Finish annealed over Copper leadframe. Solderable per MIL-STD-202, Method 208

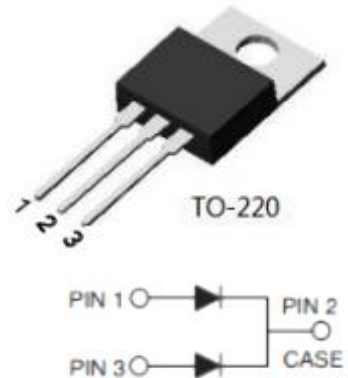

Part No.	Package	Marking	ROHS Status	Packing
SBT20L100CT	TO-220	SBT20L100CT	Pb-Free	50PCS/ (Tube)

MAXIMUM RATINGS($T_A=25\text{ }^\circ\text{C}$ unless otherwise noted)

PARAMETER	SYMBOL	VALUE	UNITS
Maximum Recurrent Peak Reverse Voltage	V_{RRM}	100	V
Maximum RMS Voltage	V_{RMS}	70	V
Maximum average forward rectified current	per device	20	A
	per diode	10	
Peak Forward Surge Current : 8.3ms single half sine-wave superimposed on rated	I_{FSM}	180	A
Typical Thermal Resistance	$R_{\theta JC}$	15	$^\circ\text{C}/\text{W}$
Operating Junction and Storage Temperature Range	T_J, T_{STG}	-40 to 150	$^\circ\text{C}$

Note :

1. Mounted on infinite heatsink.

ELECTRICAL CHARACTERISTICS ($T_A=25\text{ }^\circ\text{C}$ unless otherwise noted)

Symbol	Parameter	Test Conditions	Min	TYP	Max	Unit	
Static Characteristics							
V_{BR}	Breakdown voltage per diode	$I_R = 100\mu\text{A}$, $T_J = 25\text{ }^\circ\text{C}$	100	-	-	V	
V_F	Instantaneous forward voltage per diode	$I_F = 2\text{A}$	$T_J = 25\text{ }^\circ\text{C}$	-	0.47	-	V
		$I_F = 3\text{A}$		-	0.53	-	
		$I_F = 10\text{A}$		-	0.654	0.70	
		$I_F = 10\text{A}$	$T_J = 125\text{ }^\circ\text{C}$	-	0.63	-	V
I_R	Reverse current per diode	$V_R = 70\text{V}$, $T_J = 25\text{ }^\circ\text{C}$	-	1.5	-	μA	
		$V_R = 100\text{V}$	$T_J = 25\text{ }^\circ\text{C}$	-	-	50	μA
			$T_J = 125\text{ }^\circ\text{C}$	-	7.2	-	mA

RATING AND CHARACTERISTIC CURVES

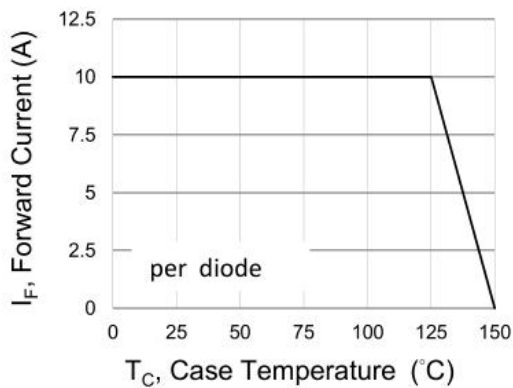

Fig.1 Forward Current Derating Curve

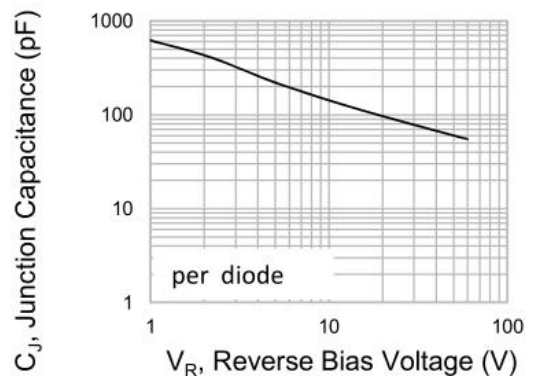

Fig.2 Typical Junction Capacitance

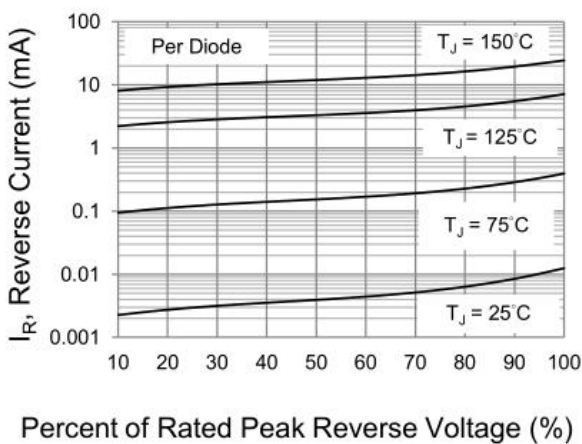

Fig.3 Typical Reverse Characteristics

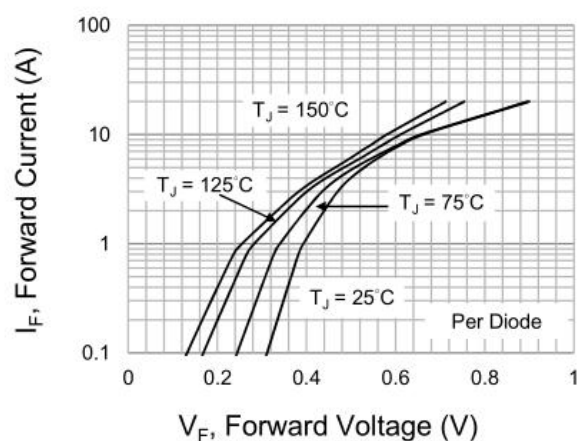
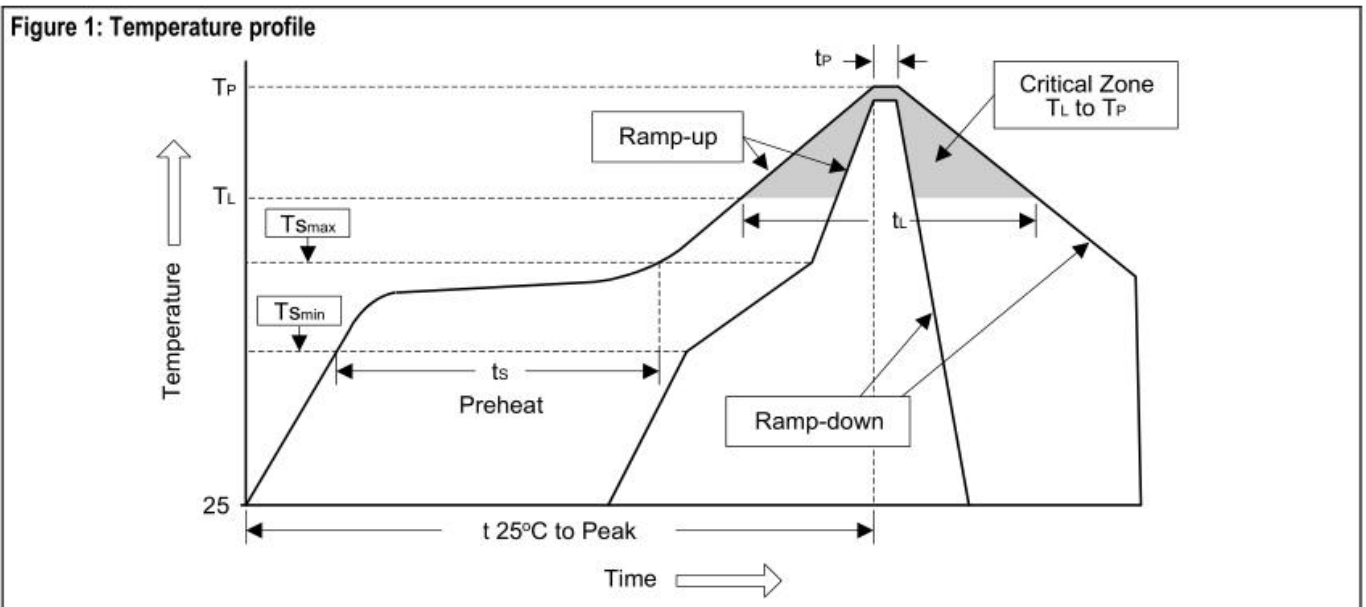

Fig.4 Typical Forward Characteristics

Soldering Methods for Products

Profile Feature	Sn-Pb Eutectic Assembly	Pb-Free Assembly
Average ramp-up rate(TL to TP)	<3°C/sec	<3°C/sec
Preheat		
-Temperature Min(Ts min)	100°C	150°C
-Temperature Max(Ts max)	150°C	200°C
-Time(min to max)(ts)	60 to 120 sec	60 to 180 sec
Ts max to TL		
- ramp-up rate	<3°C/sec	<3°C/sec
Time maintained above:		
-Temperature(TL)	183°C	217°C
-Time(t L)	60 to 150 sec	60 to 150 sec
Peak Temperature(T p)	240°C+0/-5°C	250°C+0/-5°C
Time within 5°C of actual Peak Temperature	10 to 30 sec	20 to 40 sec
Ramp-down Rate	<6°C/sec	<6°C/sec
Time 25 °C to Peak Temperature	<6 minutes	<8 minutes



- Note :**
- 1.Storage environment: Temperature=10°C to 35@Humidity=45%±15%
 - 2.Reflow soldering of surface-mount devices
 - 3.Flow(wave) soldering(solder dipping)

Products	Peak Temperature	Dipping Time
Pb devices	245°C±5°C	5sec±1sec
Pb-free devices	250°C+0/-5°C	5sec±1sec

Package Outline

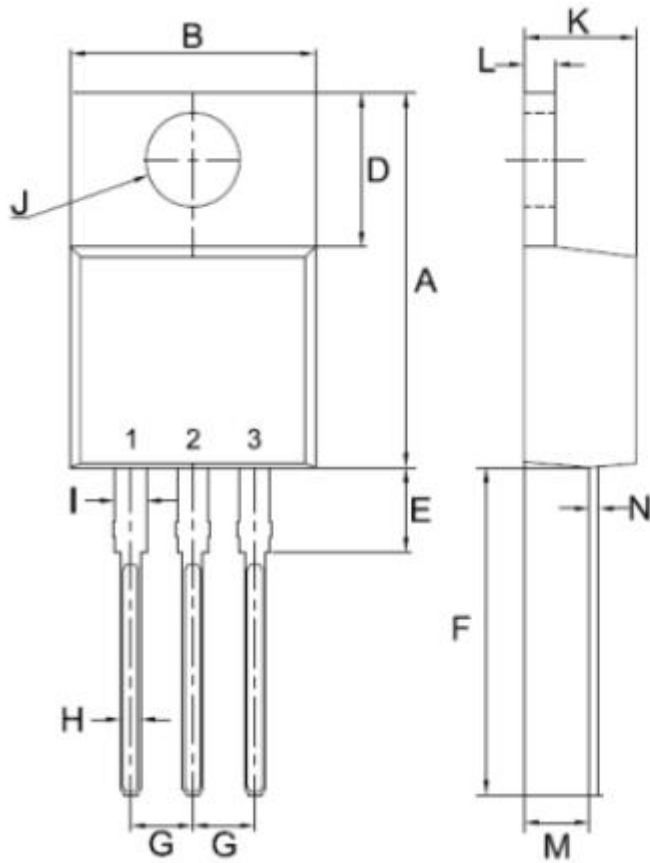

TO-220AB		
Unit:mm		
DIM	MIN	MAX
A	14.80	15.80
B	9.57	10.57
D	5.80	6.80
E	2.95	3.95
F	12.70	13.40
G	2.34	2.74
H	0.51	1.11
I	0.97	1.57
J	3.54 ϕ	4.14 ϕ
K	4.27	4.87
L	1.07	1.47
M	2.03	2.92
N	0.30	0.64

■ Important Notice

Si-Trend reserves the right to change all product 、 product specifications and data without prior notice ; Our customer Please confirm to place an order confirmation before make the integrity of information complete and up-to-date ◦

Any semiconductor under specific conditions are possible to certain failure or malfunction rate ; Customers are responsible in the use of Si-Trend products to system design and manufacturing in compliance with safety standards and adopting safety measures , To avoid the potential risk of failure may cause the personal safety and property loss ◦

Si-Trend Always refine on to provide more excellent products

■ Modify record

Date	Version	Description	Pagination
20160626	A.0	original	5
20190828	A.1	/	5