

---

## 3-Channel Supervisor IC for Power Supply

### Features

- Over-voltage protection and lockout
- Under-voltage protection and lockout
- Open drain power good output signal
- Built-in 300mS delay for power good
- 38mS de-bounce for PSON/ control
- 73uS de-bounce for noise immunity
- Wide power supply range

### Applications

- PC power supply
- LCD TV power supply

### Description

SI8260DTR is designed to monitor the outputs of switching power supply and generate the power good signal to inform the system. There are three important functions of SI8260DTR: over-voltage protection, under-voltage protection and power good signal generating.

Over-voltage protection (OVP) monitors 3.3V, 5V and 12V to protect the power supply and system when one of these supply voltages exceeds their normal operation voltage.

Under-voltage protection (UVP) monitors 3.3V, 5V and 12V to protect the power supply and system. When power supply is ready or going to shutdown, power good signal generating notifies personal computers ;it provides a reliable power supply environment for system.

## Pin Configuration

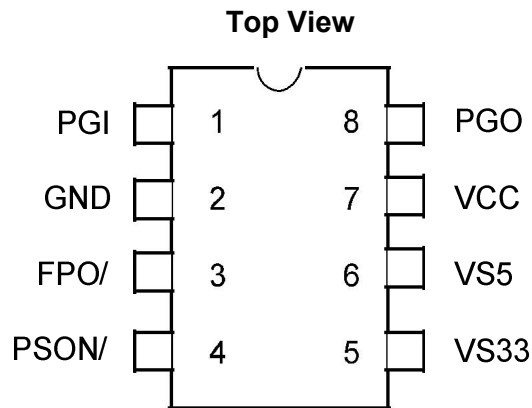

## Pin Descriptions

Pin No.	Name	Function
1	PGI	Power good input signal pin
2	GND	Ground
3	FPO/	Inverted fault protection output, open drain output stage
4	PSON/	Remote ON/OFF control input pin
5	VS33	3.3V over/under voltage protection input pin
6	VS5	5.0V over/under voltage protection input pin
7	VCC	Power supply
8	PGO	Power good output signal pin, open drain output stage

## Absolute Maximum Ratings

VCC, PGI, FPO/	-----	-0.5 ~ 16V
VS5, VS33, PSON/, PGO	-----	-0.5 ~ VCC + 0.5V
Junction temperature	-----	150°C
Operating ambient temperature	-----	-20°C ~ 85°C
Storage temperature range	-----	-65°C ~ 150°C
DIP-8 package thermal resistance	-----	100°C/W
Power dissipation (DIP-8, at ambient temperature = 85°C)	-----	650mW
Lead temperature (All Pb free packages, soldering, 10 sec)	-----	260°C
ESD voltage protection, human body model	-----	3KV
ESD voltage protection, machine model	-----	250V

## Recommended Operating Conditions

Item	Min.	Max.	Unit
Supply voltage VCC	4.5	15	V

## Block Diagram

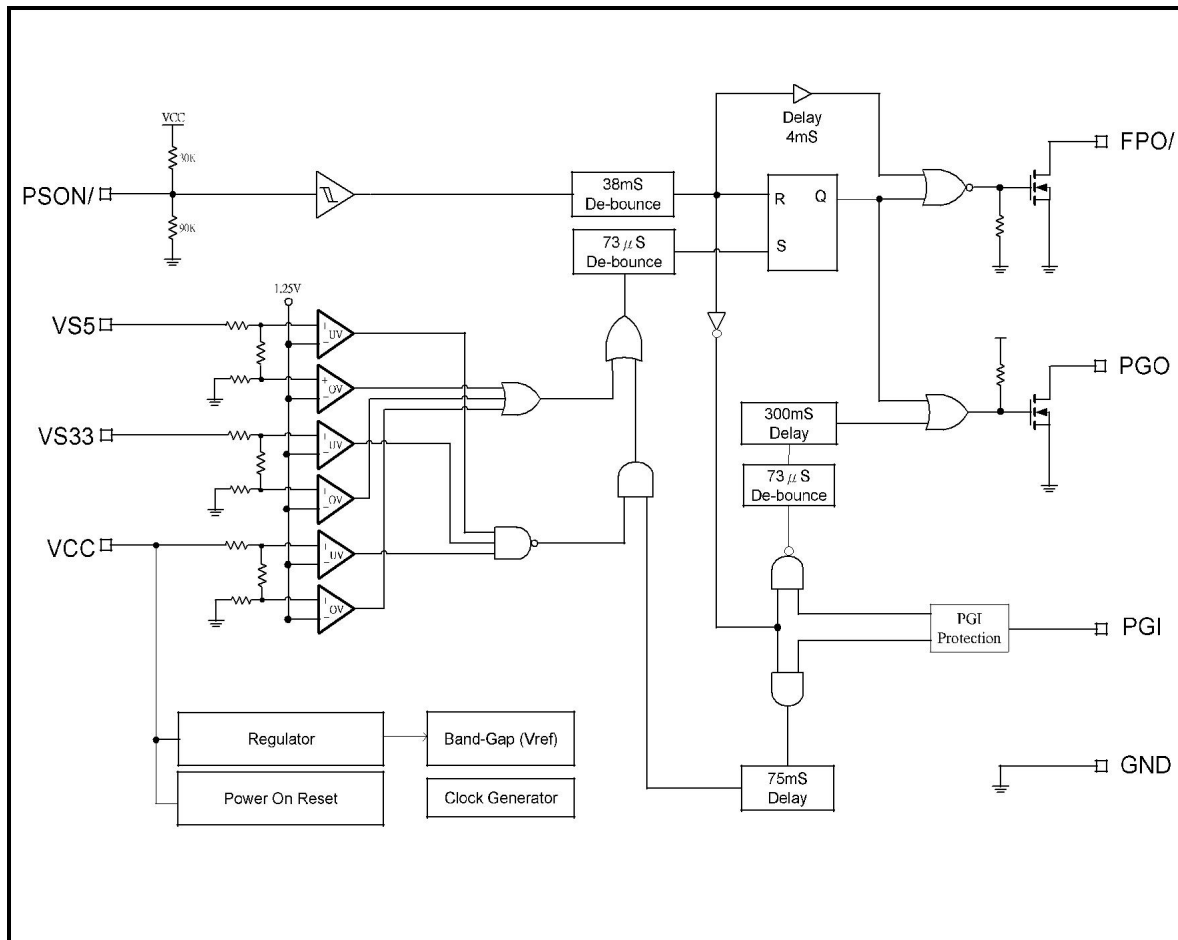

## Timing Chart

### 1. PSON/ Signal Characteristics

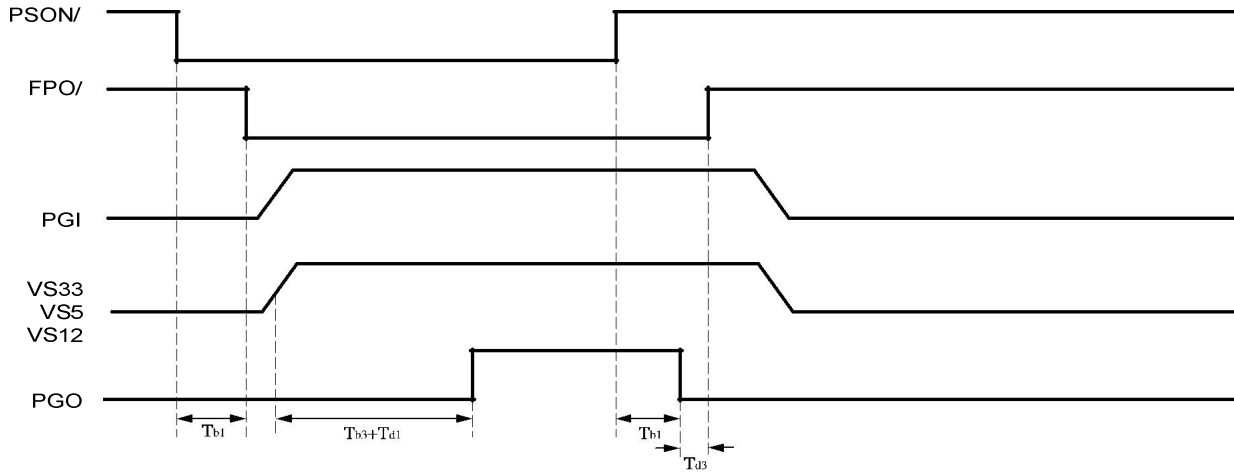

### 2. Over-Voltage Characteristics

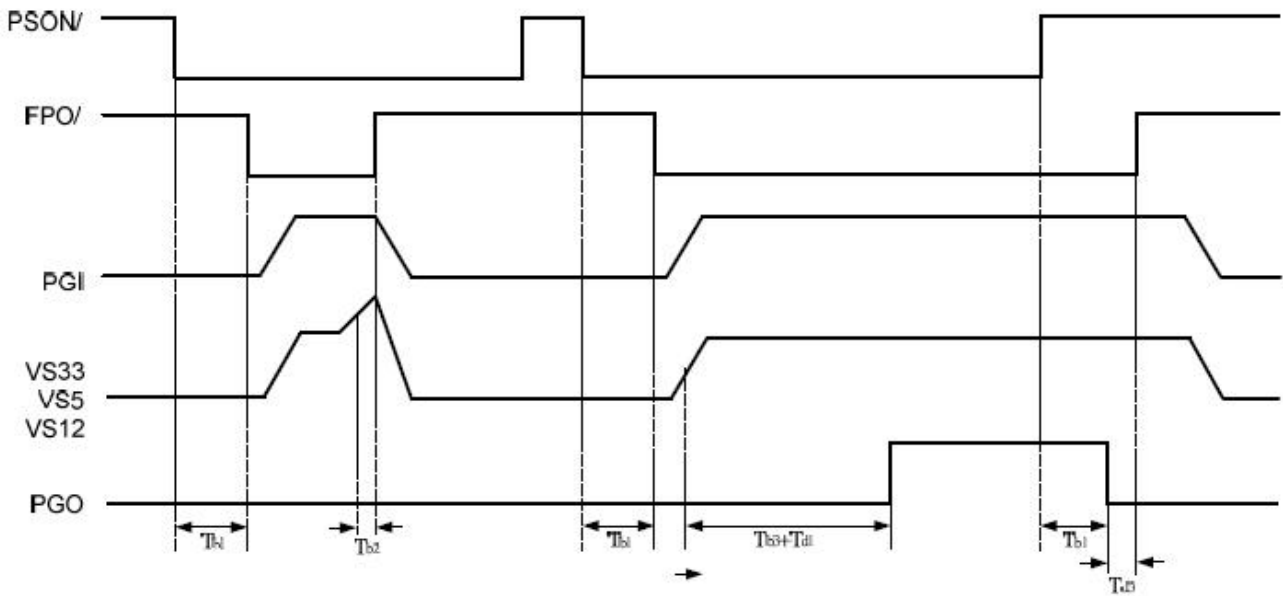

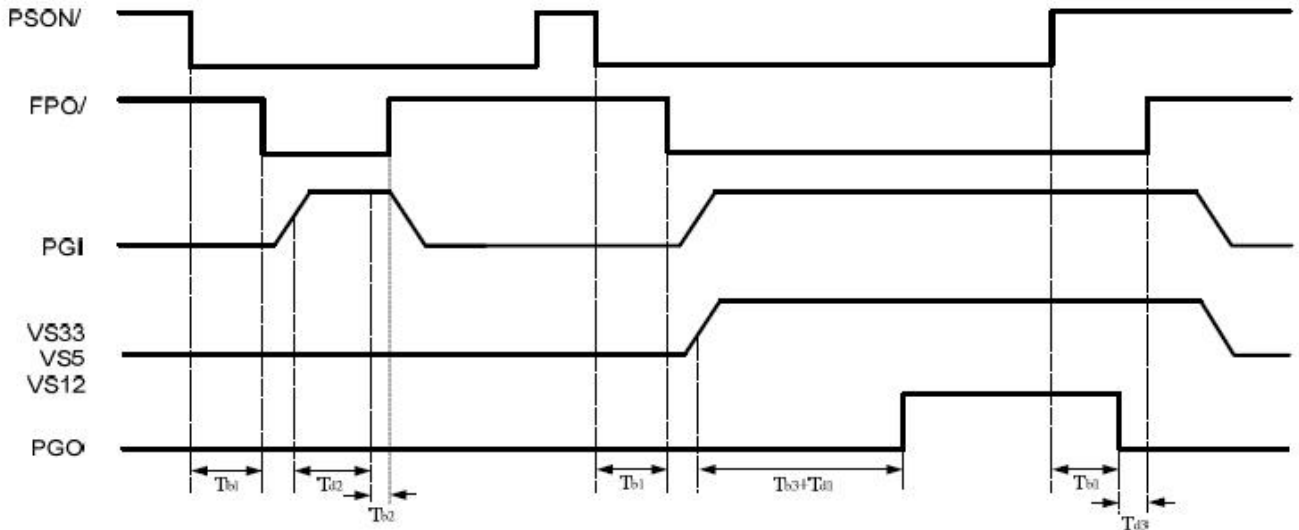
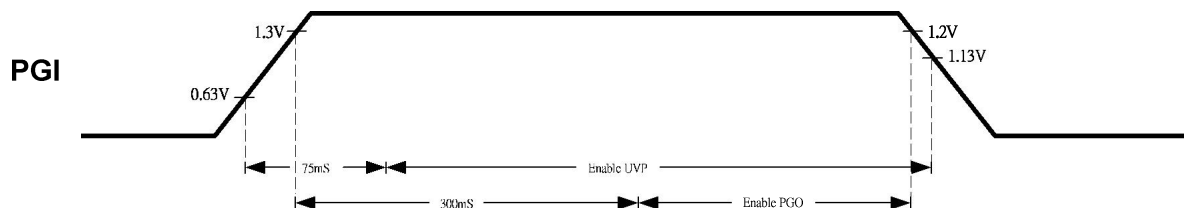
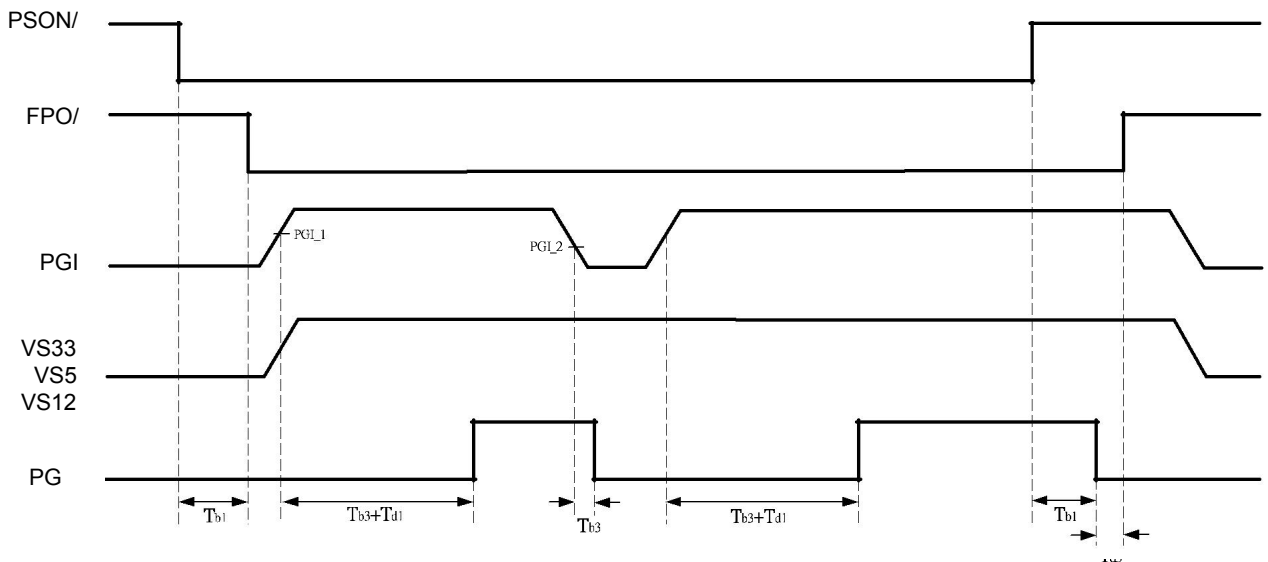
**Timing Chart (Cont.)**
**3. Under-Voltage Characteristics**

**4. PGI Characteristics**

**Electrical Characteristics** ( $T_A = +25\text{ }^\circ\text{C}$  unless otherwise stated,  $V_{CC} = 12.0\text{V}$ )

Parameter	Conditions	Symbol	Min.	Typ.	Max.	Unit
-----------	------------	--------	------	------	------	------

**POWER SUPPLY**

Supply voltage		VCC	4.0	5.0	16.0	V
Supply current	$V_{PSON/} = 5\text{V}$	Ivcc		2	3	mA

**OVER-VOLTAGE PROTECTION**

Over-voltage threshold		VS33	3.7	3.9	4.1	V
		VS5	5.7	6.1	6.5	V
		VS12	13.2	13.8	14.4	V

**UNDER-VOLTAGE PROTECTION**

Under-voltage threshold		VS33	2.0	2.2	2.4	V
		VS5	3.3	3.5	3.7	V
		VS12	8.5	9.0	9.5	V

**PSON/**

High-level input threshold voltage		$V_{IH}$	1.4	1.5		V
Low-level input threshold voltage		$V_{IL}$		1.0	1.1	V

**PGI AND PGO, FPO/**

PGI threshold voltage	PGI_1	$V_{PGI,1}$		1.3	1.37	V
	PGI_2	$V_{PGI,2}$	1.13	1.2		V
Threshold voltage for Td2		$V_{PGI,Td2}$	0.6	0.63	0.75	V
Disable UVP threshold voltage			1.05	1.13	1.21	V
Leakage current (PGO)	$V_{PGO} = 5\text{V}$	$I_{LKG}$			5	uA
Low level output voltage (PGO)	$I_{SINK} = 10\text{mA}$	$V_{OL}$			0.35	V
Leakage current (FPO/)	$V_{FPO/} = 5\text{V}$	$I_{LKG}$			5	uA
Low level output voltage(FPO/)	$I_{SINK} = 10\text{mA}$	$V_{OL}$			0.35	V

**SWITCHING CHARACTERISTICS**

PSON/ de-bounce time		Tb1	24	38	61	mS
FPO/ Noise de-glitch time		Tb2	47	73	110	uS
PGO Noise de-glitch time		Tb3	47	73	110	uS
PGI to PGO delay time		Td1	200	300	480	mS
UVP protection delay time		Td2	49	75	114	mS
PGO to FPO/ delay time		Td3	2	4	6	mS

## Function Table

PGI	PSON_N	UV	OV	FPO/	PGO
< 0.63V	L	No	No	L	L
< 0.63V	L	No	Yes	H	L
< 0.63V	L	Yes	No	L	L
0.63V < PGI < 1.3V	L	No	No	L	L
0.63V < PGI < 1.3V	L	No	Yes	H	L
0.63V < PGI < 1.3V	L	Yes	No	H	L
PGI > 1.3V	L	No	No	L	H
PGI > 1.3V	L	No	Yes	H	L
PGI > 1.3V	L	Yes	No	H	L
X	H	X	X	H	L

X = Don't care

## Typical Application Circuit

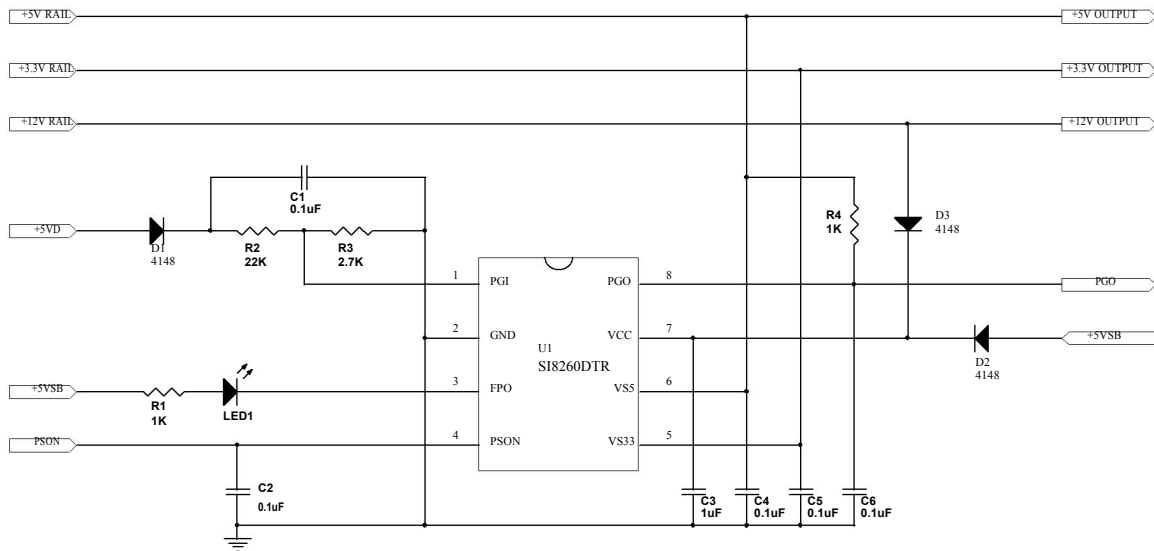

## Application Information

1. The power supply bypass capacitor C3 suggests to be 0.1uF ~ 10uF and around the VCC pin and GND pin while layout. Other bypass capacitors suggests to be 0.01uF ~ 1uF.

## Package Information

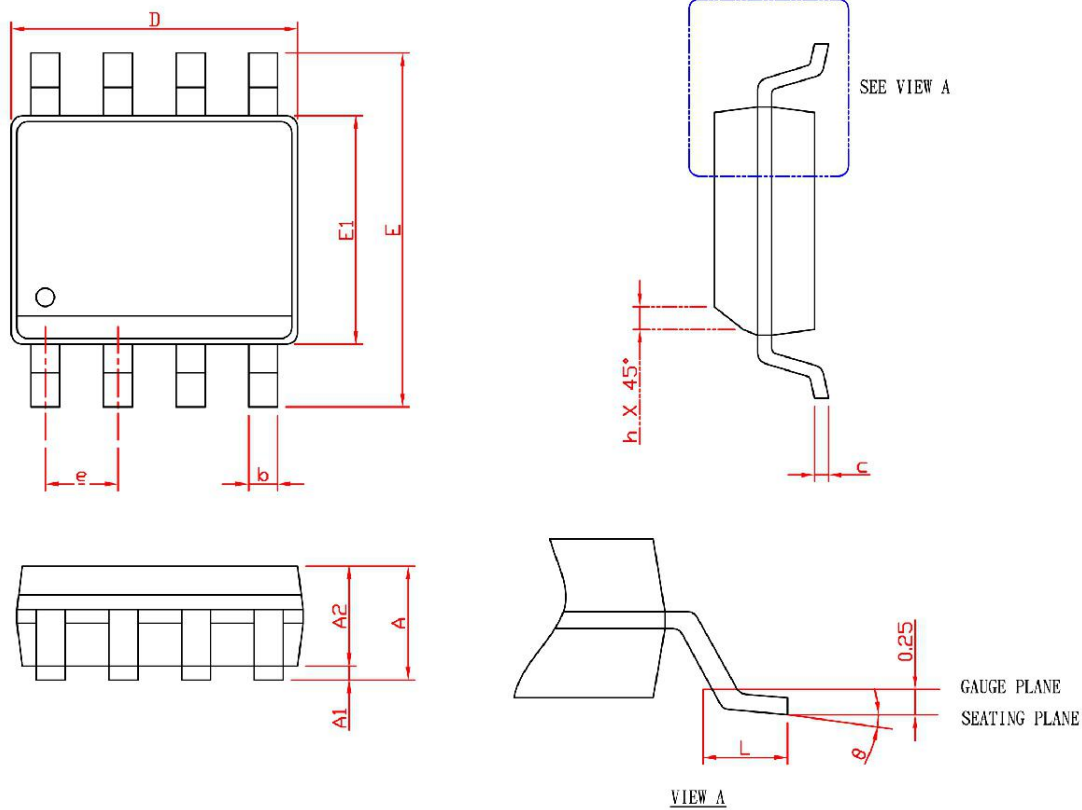

SYMBOL	SOP-8			
	MILLIMETERS		INCHES	
	MIN.	MAX.	MIN.	MAX.
A		1.75		0.069
A1	0.10	0.25	0.004	0.010
A2	1.25		0.049	
b	0.31	0.51	0.012	0.020
c	0.17	0.25	0.007	0.010
D	4.80	5.00	0.189	0.197
E	5.80	6.20	0.228	0.244
E1	3.80	4.00	0.150	0.157
e	1.27 BSC		0.050 BSC	
h	0.25	0.50	0.010	0.020
L	0.40	1.27	0.016	0.050
	0°	8°	0°	8°

Note: 1. Followed from JEDEC MS-012 AA.

2. Dimension "D" does not include mold flash, protrusions or gate burrs. Mold flash, protrusion or gate burrs shall not exceed 6 mil per side.

3. Dimension "E1" does not include inter-lead flash or protrusions. Inter-lead flash and protrusions shall not exceed 10 mil per side.



## Package Information

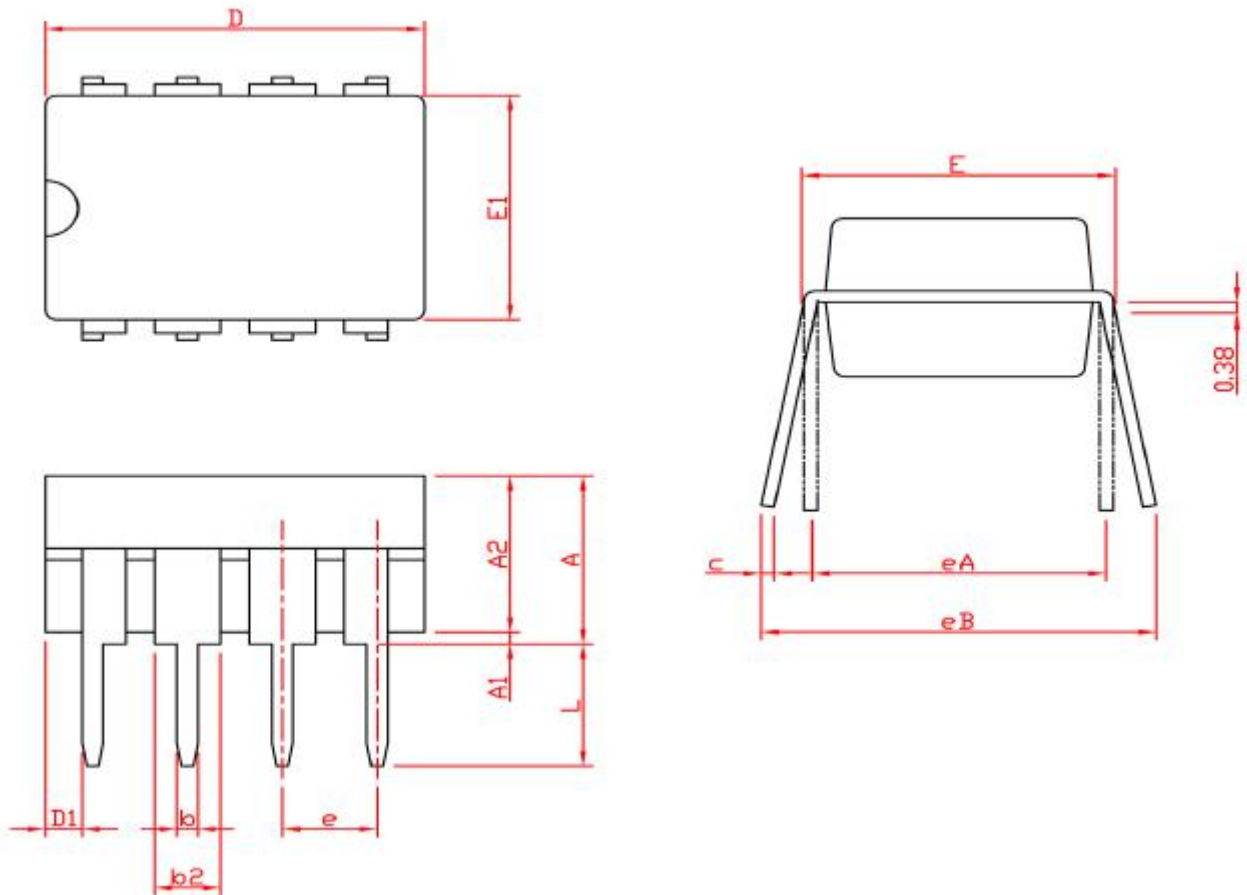

SYMBOL	DIP-8			
	MILLIMETERS		INCHES	
	MIN.	MAX.	MIN.	MAX.
A		5.33		0.210
A1	0.38		0.015	
A2	2.92	4.95	0.115	0.195
b	0.36	0.56	0.014	0.022
b2	1.14	1.78	0.045	0.070
c	0.20	0.35	0.008	0.014
D	9.01	10.16	0.355	0.400
D1	0.13		0.005	
E	7.62	8.26	0.300	0.325
E1	6.10	7.11	0.240	0.280
e	2.54 BSC		0.100 BSC	
eA	7.62 BSC		0.300 BSC	
eB		10.92		0.430
L	2.92	3.81	0.115	0.150

Note: 1. Followed from JEDEC MS-001 BA

2. Dimension D, D1 and E1 do not include mold flash or protrusions. Mold flash or protrusions shall not exceed 10 mil.

## Carrier Tape & Reel Dimensions

SOP- 8

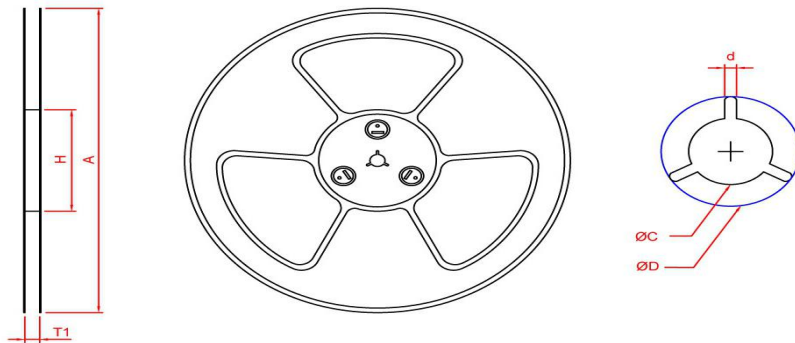
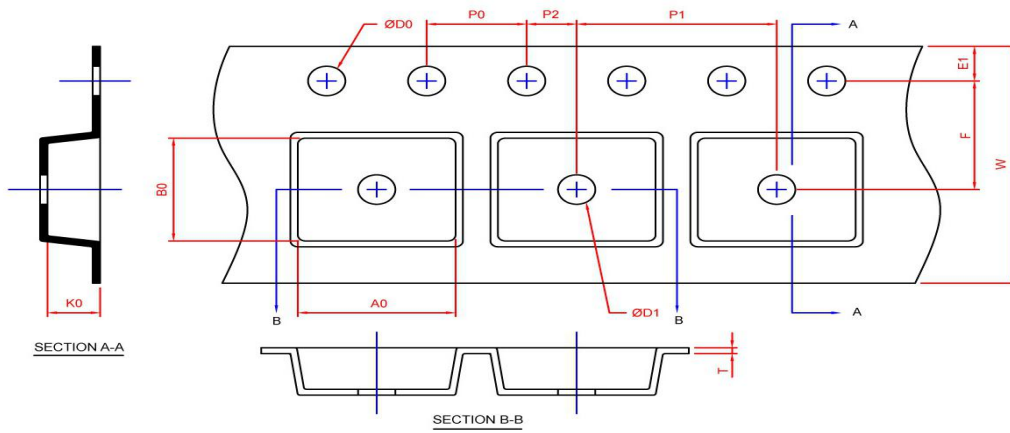

Application	A	H	T1	C	d	D	W	E1	F
SOP-8	330.0 2.0 ±	50 MIN.	12.4+2.00 -0.00	13.0+0.50 -0.20	1.5 MIN.	20.2 MIN.	12.0 0.30 ±	1.75 0.10 ±	5.5 0.05 ±
	<b>P0</b>	<b>P1</b>	<b>P2</b>	<b>D0</b>	<b>D1</b>	<b>T</b>	<b>A0</b>	<b>B0</b>	<b>K0</b>
	4.0 0.10 ±	8.0 0.10 ±	2.0 0.05 ±	1.5+0.10 -0.00	1.5 MIN.	0.6+0.00 -0.40	6.40 0.20 ±	5.20 0.20 ±	2.10 0.20 ±

(mm)

### Devices Per Unit

Application	Carrier Width	Cover Tape Width	Devices Per Reel
SOP- 8	12	-	2500