

8A 600V Fast Recovery Epitaxial Diode(FRED)

$I_F(AV)$	8A
V_{RRM}	600 V
$T_j(max)$	175°C
$V_F(typ)$	2.2V
$T_{rr}(typ)$	16ns

Features

- Ultrafast Recovery
- Soft Recovery Characteristics
- Low Forward Voltage
- Low stored Charge
- Low Leakage Current
- Low Recovery Loss

Applications

- Case: TO-220F
- Active power factor correction
- Switch Power Supplies
- Inverters Converters
- PFC UPS

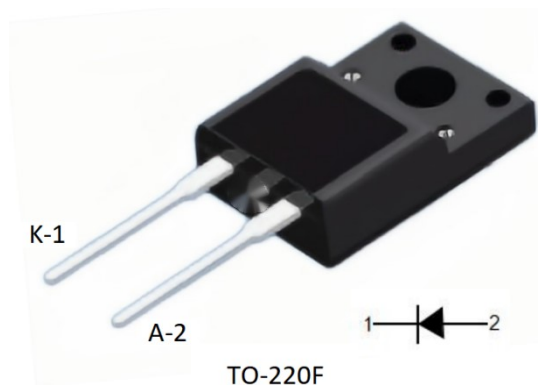
Pin Description

Part Number	Package	Marking	ROHS Status	Packing
SI8U600F	TO-220F	SI8U600F	Pb-Free	Box(Tube)

Absolute Maximum Ratings ($T_A=25^\circ\text{C}$ unless otherwise noted)

Symbol	Parameter	Value	Unit
V_{RRM}	Maximum Recurrent Peak Reverse Voltage	600	V
V_{RMS}	Maximum rms voltage	450	V
V_R	Maximum dc blocking voltage	600	V
$I_{F(AV)}$	Maximum average forward rectified current	8	A
I_{FSM}	Peak one Cycle Surge Forward Current(Non-Repetitive) $t=8.3ms$	80	A
T_j	Junction Temperature	-50~+175	°C
T_{STG}	Storage temperature range	-50~+175	°C

Thermal Characteristics

Symbol	Parameter	Value	Unit
$R_{\theta JC}$	Thermal resistance from junction to case	3.5	$^{\circ}\text{C}/\text{W}$

Electrical Characteristics ($T_A=25^{\circ}\text{C}$ unless otherwise noted)

Symbol	Parameter	Test Conditions	Min	TYP	Max	Unit
Static Characteristics						
V_{BR}	Reverse Breakdown Voltage	$I_R=100\ \mu\text{A}$	600	-	-	V
V_F	Instantaneous forward voltage per diode	$I_F=8\ \text{A}, PW=0.3\ \text{mS}$ $T_a=25\ ^{\circ}\text{C}$	-	2.2	2.5	V
		$I_F=8\ \text{A}, PW=0.3\ \text{mS}$ $T_a=125\ ^{\circ}\text{C}$	-	1.8	2.05	V
I_R	Reverse current per diode	$V_R=600\ \text{V}, T_a=25\ ^{\circ}\text{C}$	-	-	50	μA
		$V_R=600\ \text{V}, T_a=125\ ^{\circ}\text{C}$	-	-	200	μA
T_{rr}	Reverse Recovery Time	$I_F=0.5\ \text{A}, I_R=1\ \text{A},$ $I_{rr}=0.25\ \text{A}$	-	-	30	ns
		$I_F=1\ \text{A}, V_R=30\ \text{V}, di/dt=-$ $100\ \text{A}/\mu\text{s}$	-	16	-	ns
		$I_F=1\ \text{A}, V_R=30\ \text{V}, di/dt=-$ $200\ \text{A}/\mu\text{s}$	-	16	-	ns
I_{RRM}	Peak recovery current	$I_F=8\ \text{A}, V_R=400\ \text{V}, di/dt$ $=-200\ \text{A}/\mu\text{s}$	-	2.2	-	A
Q_{RR}	Reverse recovery charge	$I_F=8\ \text{A}, V_R=400\ \text{V}, di/dt$ $=-200\ \text{A}/\mu\text{s}$	-	32	-	nC

Remark:

1. Customer should obtain the latest version of data sheet before placing order, and verify the relevant information.

Typical Performance Characteristics

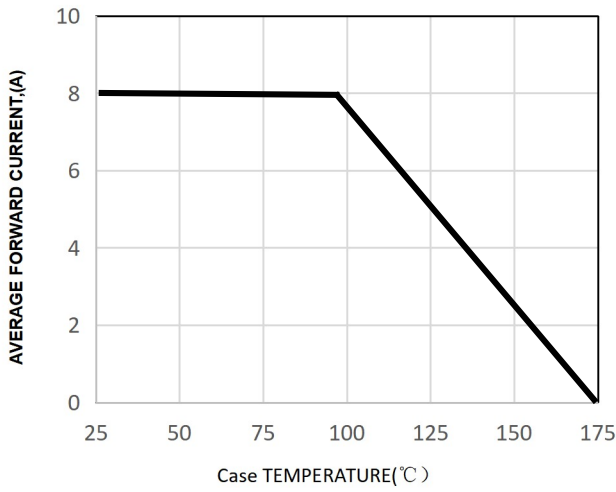

Fig.1 Typical Forward Current Derating Curve

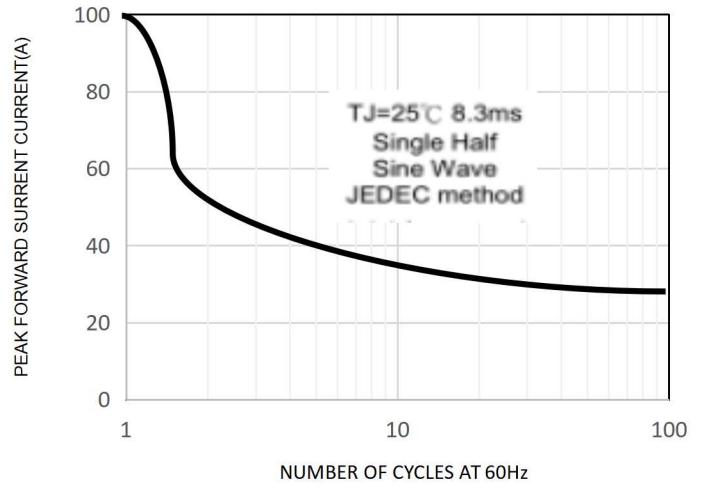

Fig.2 -Maximum Non-Repetitive Forward Surge Current

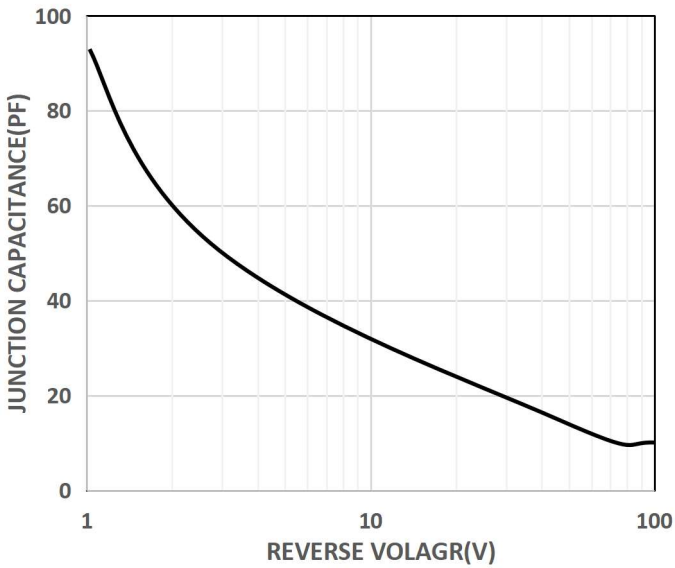

Fig.3 Typical Junction Characteristics

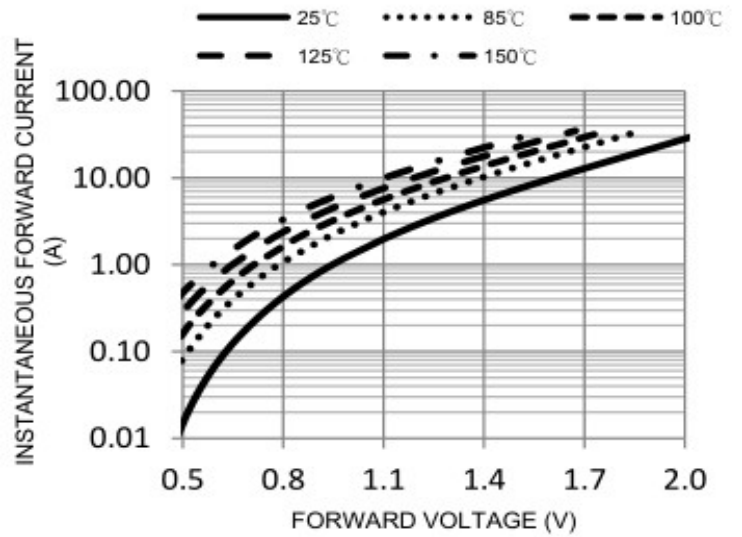

Fig.4 Typical Forward Characteristics

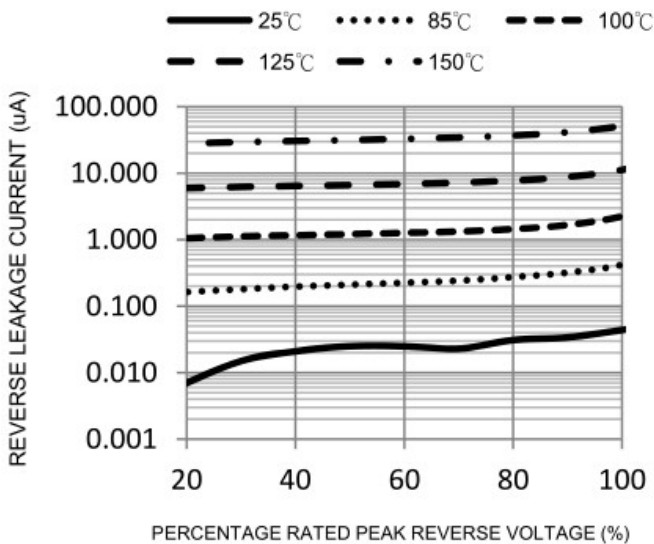
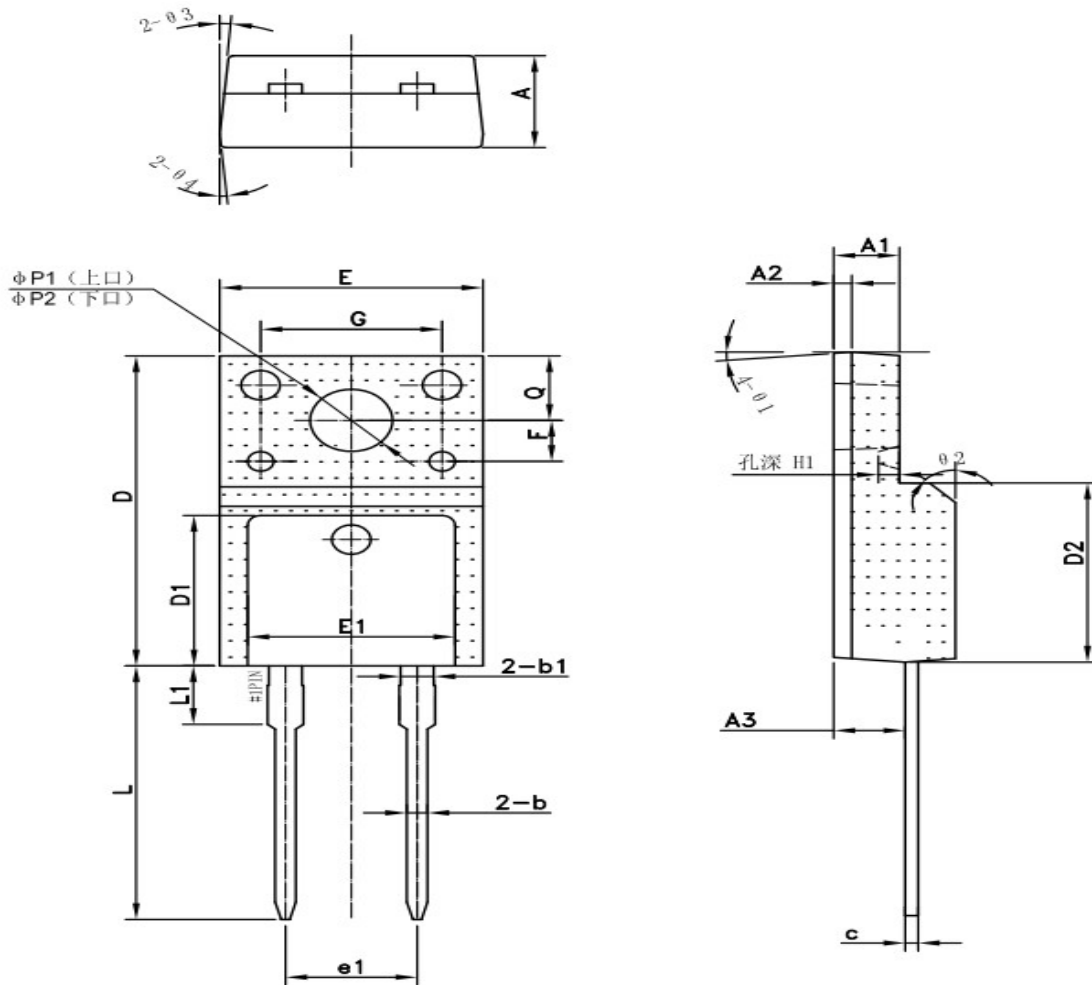

Fig.5 Typical Reverse Characteristics

Package Outline

Millimeters					
Symbol	Min	Max	Symbol	Min	Max
A	4.50	4.90	E	9.86	10.36
A1	2.30	2.80	E1	8.00 Typ.	
A2	0.7 Typ.		e1	5.08 Typ.	
A3	2.54	2.96	F	2.1 Typ.	
b	0.7	0.95	G	7.0 Typ.	
b1	1.28 Typ.		H1	0.81 Typ.	
c	0.45	0.65	L	12.40	13.20
D	15.57	16.10	L1	2.93 Typ.	
D1	7.70 Typ.		Q	3.10	3.50
D2	9.12 Typ.		θ 1	5°	
θ 2	45°		θ 3	5°	
θ 4	5°		P1 (上口)	2.98	3.38
P2 (下口)	3.20	3.60			

Soldering Methods for Products

Profile Feature	Sn-Pb Eutectic Assembly	Pb-Free Assembly
Average ramp-up rate(TL to TP)	<3°C/sec	<3°C/sec
Preheat -Temperature Min(Ts min) -Temperature Max(Ts max) -Time(min to max)(ts)	100°C 150°C 60 to 120 sec	150°C 200°C 60 to 180 sec
Tsmax to TL - ramp-up rate	<3°C/sec	<3°C/sec
Time maintained above: -Temperature(TL) -Time(tL)	183°C 60 to 150 sec	217°C 60 to 150 sec
Peak Temperature(Tp)	240°C+0/-5°C	250°C+0/-5°C
Time within 5°C of actual Peak Temperature	10 to 30 sec	20 to 40 sec
Ramp-down Rate	<6°C/sec	<6°C/sec
Time 25 °C to Peak Temperature	<6 minutes	<8 minutes

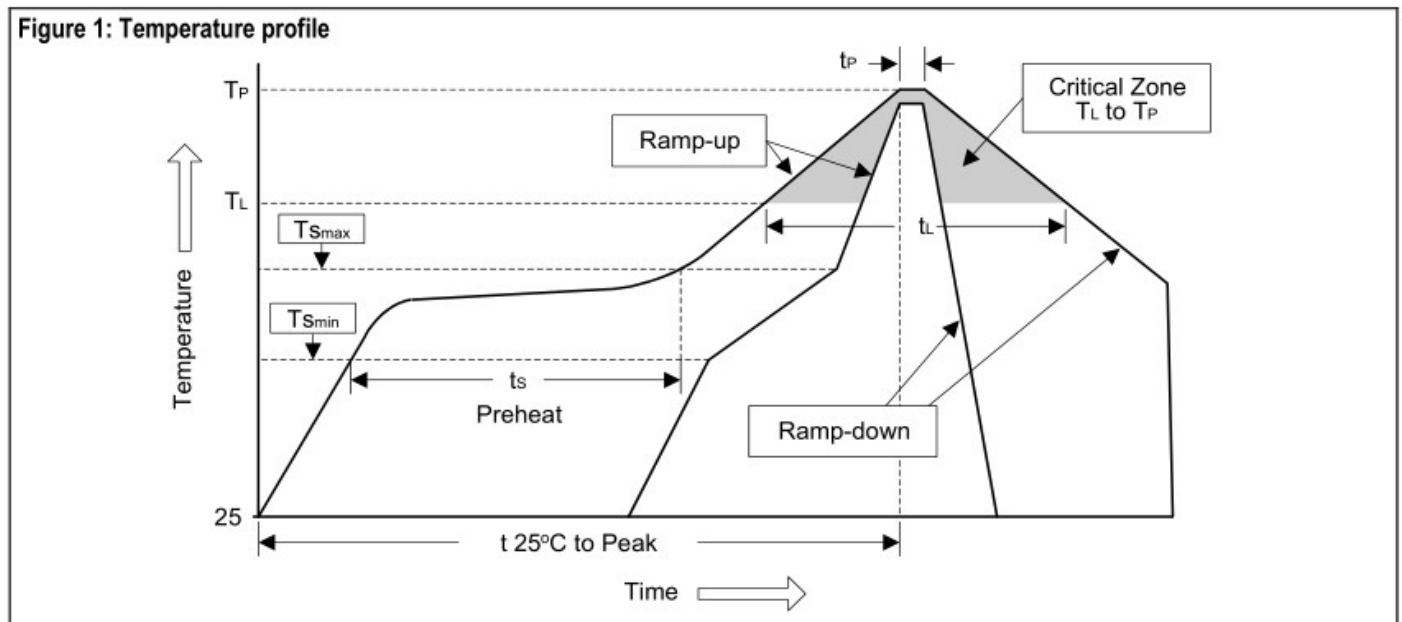
Figure 1: Temperature profile

Note: 1.Storage environment: Temperature=10°C to 35@Humidity=45%±15%
 2.Reflow soldering of surface-mount devices
 3.Flow(wave) soldering(solder dipping)

Products	Peak Temperature	Dipping Time
Pb devices	245°C±5°C	5sec±1sec
Pb-free devices	250°C+0/-5°C	5sec±1sec

■ Important Notice

Si-Trend reserves the right to change all product、 product specifications and data without prior notice; Our customer Please confirm to place an order confirmation before make the integrity of information complete and up-to-date.

Any semiconductor under specific conditions are possible to certain failure or malfunction rate; Customers are responsible in the use of Si-Trend products to system design and manufacturing in compliance with safety standards and adopting safety measures, To avoid the potential risk of failure may cause the personal safety and property loss.

Si-Trend Always refine on to provide more excellent products.

■ Modify record

Date	Version	Description	Pagination
20190325	V.0	original	6
20230810	V.1	update	6